

AQ300 Steam Boiler Water Quality management System

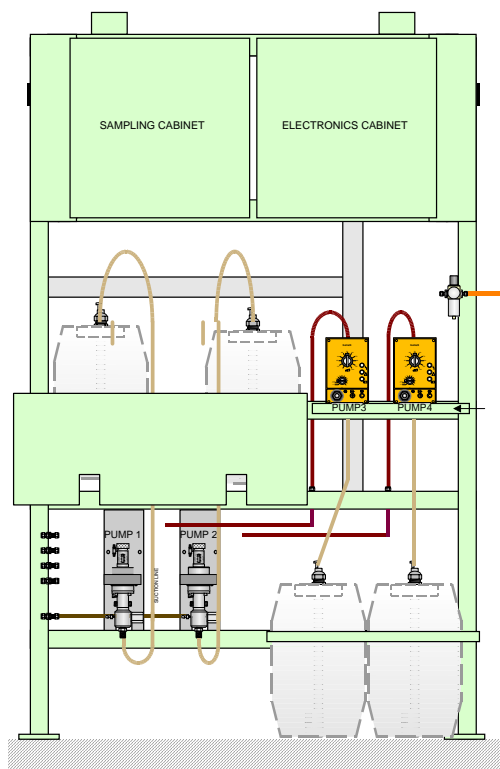

Designed for marine steam boiler installations, the AQ300 accurately monitors the boiler and feed water conditions. It injects exactly the required amount of chemicals and provides auto surface blow down control. It keeps the entire plant within the desired chemical limits, 24 hours a day, regardless of load.

The units can be fitted with a mixture of pumps of pumps and programmed for different pressure boilers and water treatment chemicals.

The system includes pH, conductivity, dissolved oxygen, temperature probes, data comm.-unit with software, feed flow meters, auto blow down valves, test kit and dosing pumps c/w suction assemblies with low level alarm.

The software provides for continuous display of all important readings and pre-formatted 'Management Reports' provide a summary of average readings for any period requested. The unit can be linked to other AQUANET systems and all readings are displayed on one monitor. The system is pre-configured for each installation and a choice of coolers, pumps, flow meters and blow down valves are available depending on vessel requirements.

Installation can be carried out by the owners staff, sub-contractor, shipyard or AQUANET personnel.

Features and Benefits

- Keeps boilers scale and corrosion free = lower operating costs
- Ensures correct chemical levels at all times = no manual control
- Easily reconfigured for new chemical suppliers = free choice
- Unique Windows Software, written for networking = ease of use
- Can be used on an existing control room PC = lower capital cost

Specifications

Description

The equipment is supplied pre-wired on a steel frame. The instrumentation is housed in a split steel cabinet with hinged lockable doors, the left hand section constructed of stainless steel, houses the sampling system and probes, the right hand section houses signal conditioning, control and the communications interface. Accommodates up to 5 samples and 5 dosing pumps

Dimensions (W) x (H) x (D) mm

Cabinets 500x 500 x 250

Frame 1240 x 2100 x 460
(assembled c/w chemical drums)

Colour – Customer specification

Rating - IP66

Power requirements

220/240 Vac 50/60 Hz. 6A Max.

Operating Temperature 50°C max.

Humidity 0-95% RH non condensing

Probes

pH

Range 0 – 14pH
Automatic temperature compensation
Sealed Reference cell
Resolution 0.5% FSD

Conductivity

Range 0-400uMhos
(other ranges available)
Automatic temperature compensation
Resolution 0.5% FSD

Dissolved Oxygen

Range 0 – 2.5 mg/litre
Automatic temperature compensation
Resolution 0.5% FSD

Feed Temperature

Stainless steel pocketed probe
0-160°C scaled as 4-20 mA signal

Communications

RS422 differential line drivers
CRC protected
Links to other AQUANET units
Optional interface to MODBUS

Flowmeters

Ultrasonic Flow Meters (Non penetrating).

Or Mechanical to suit pipe work

Clamps onto outside of existing pipe work.
Transducer maximum operating temperature 200°C

Blowdown Valves

Mechanically operated 32 bar

Or Pneumatic, with remote position indication.
Rated 100 bar to suit application

Chemical dosing pumps

Air operated 2.1 litre/hr max 500 bar (max) stainless steel
Electrically operated diaphragm pump 1 litre/hr into 16 bar (max)

Additional standard features

- Flushing water system with flow monitoring.
- Dosing pump manual speed control
- Dosing pump vent system, returns chemical to drum (No spillage)
- Fuse failure alarms
- Auto probe calibration on the unit

TYPICAL SCHEMATIC OF AN AQUANET LOW PRESSURE SYSTEM

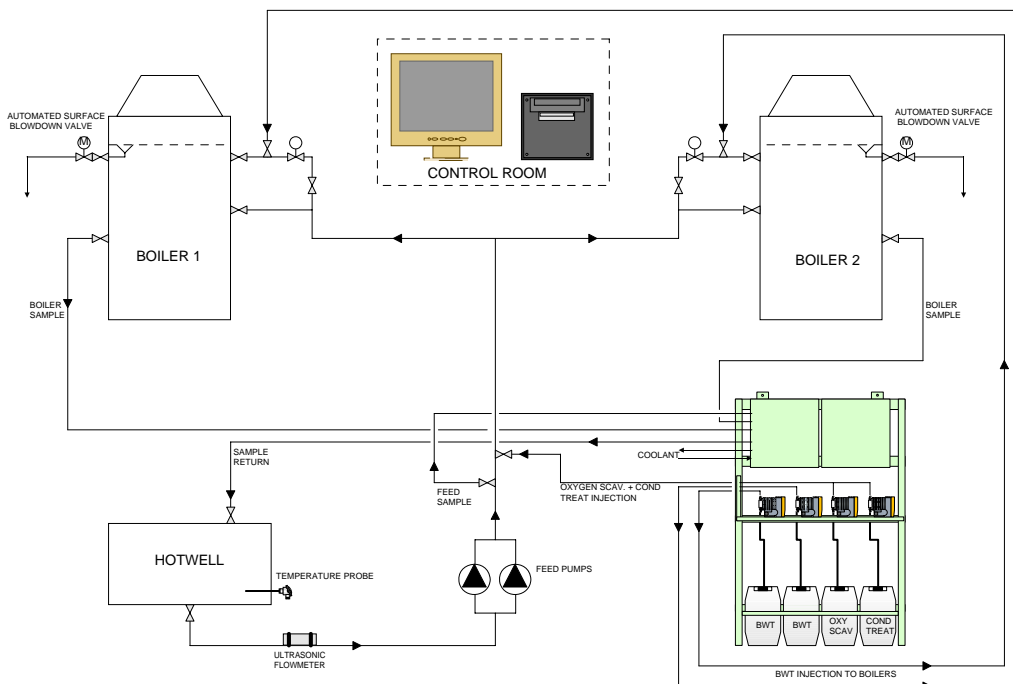

Description of Operation

A sample from the feed system and each boiler is selected by each controller on a continuous cycle. The samples are cooled, pressure reduced and then passed through the probe block. The samples are analysed and the information is processed by the program, followed by an adjustment of the relevant injection pumps. The boiler water conductivity automatically controls the modulation of the surface blow down valves, giving timed blow down periods via a built in orifice. This accurately maintains the water at the ideal density for maximum chemical performance with minimum waste.

Flow Management

The system provides a continuous display for all boilers, feed water, condensate and total main feed. The display can be cumulative, average rate per minute and hour.

This data not only assists in the control of the water chemistry but also provides information indicating the source of feed losses and steam production. A useful maintenance tool.

Chemical consumption

An indication of the chemical consumption is also displayed.

User Guide

The AQUANET PC comes complete with a comprehensive user guide, which contains on-line copies of the operating, maintenance and fault finding manuals. It includes system drawings both mechanical and electrical and educational text describing water treatment practice.

Event Alarms

Fault and limit alarms are both displayed on the screen and logged. They have a unique feature of a warning box appearing on the screen, which provides practical advice and instructions on corrective action.

Log Reports

Pre-formatted management reports provide a summary of average monthly readings, with comments on those which are persistently out of range. All reports and data can be viewed and printed for any period requested and are also available in various graphic formats. All data is archived for many years.

Auto-Calibrate

All probes are easily calibrated with the test kit provided and via easy to follow, on-screen, step-by-step instructions. It takes only minutes to carry out accurately, preventing the use of incorrect parameters.